



P8



## L/C/R/Surround Speaker Technical Specifications



- Upgraded February 2012 with new enclosure, 8" woofer and crossover
- Main and surround speaker for mid to large-size rooms
- Main speaker for rooms 15 to 30 feet deep
- THX Approved for integration into professional rooms, including THX Certified Screening Rooms and THX pm3 Studios
- 1.5" compression driver on elliptical constant directivity waveguide:  
80°H x 50°V from 1.5kHz
- High-output 8" woofer with 1.5" (40mm) VC
- Identical Voice™ timbre-matched to Procella P860, P815, P610 and P6
- Back baffle angled at 7°
- Sealed-box design
- Shallow depth (7.9" deep)
- Mounting bracket included

**Impedance** 8 Ohms nominal  
Above 12 Ohms in working range,  
phase angles less than 30 degrees

**Power handling**  
*Continuous* 250 Watt  
*Peak* 1,000 Watt

**Sensitivity**  
*1m/1W* 92dB

**Maximum SPL**  
*free-standing* 116dB continuous, 122dB peak  
*in baffle wall* 122dB continuous, 128dB peak

**Frequency response**  
*-3dB points* 80Hz and 20kHz

**Dispersion pattern**  
*-6dB* Constant directivity;  
80°H x 50°V from 1.5kHz

**Crossover** 4th Order Linkwitz-Reilly  
1.6 KHz, BSC

**Components**  
*Midrange* 8" high output driver with 40mm  
voice coil in 15 litre sealed box  
*High Frequency* 1.5" driver with a Polyester diaphragm on  
elliptical constant directivity wave guide

**Connectivity** Gold plated binding posts

**Construction** Void free MDF internally cross braced  
Studio vinyl finish as standard

**Dimensions**  
*HxWxD* 16.125" x 17.7" x 7.875 / 5.4" (7° tilt)  
410 x 450 x 200 / 138 mm (7° tilt)

**Shipping Carton**  
*HxWxD* 19.1" x 21.5"x 11.6" / 485 x 545 x 295 mm

**Net weight** 34.2 Lbs / 15.5 Kg

**Shipping weight** 37.5 Lbs / 17.0 Kg

**Included** Wall mount bracket

**Assembly** Sweden; 100% QC testing

# P8

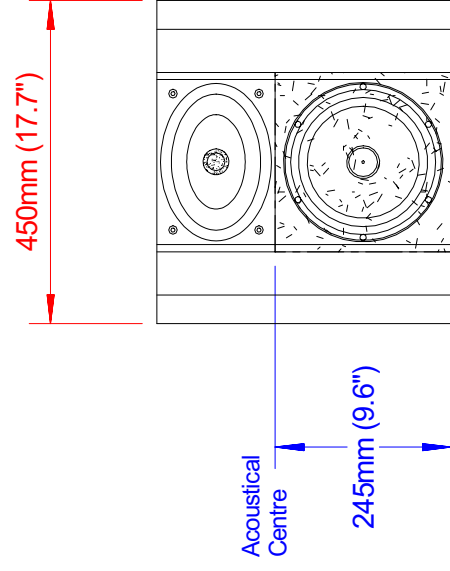
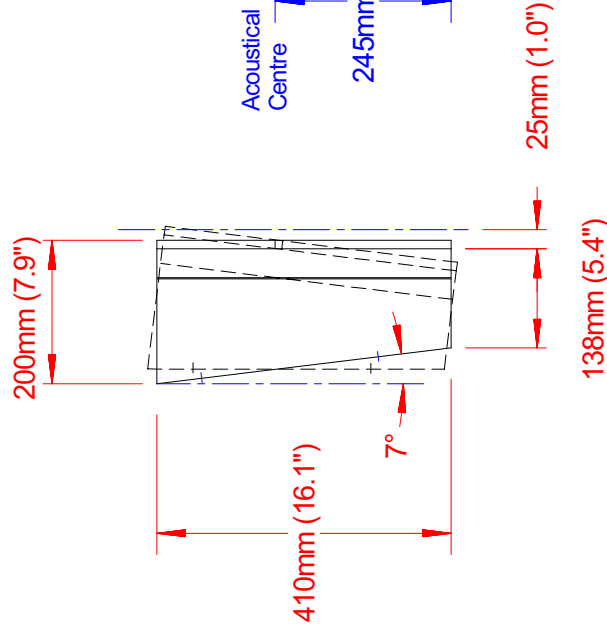
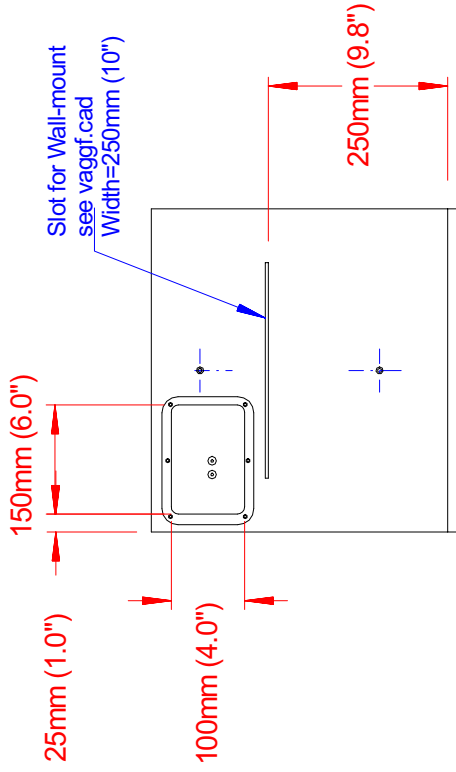
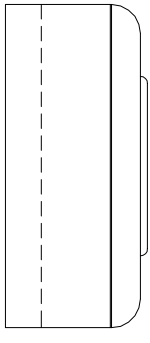

Baffle wall cut-out = 500 x 440mm (19-3/4" x 17-3/8")  
Weight = 15.5kg (34.2Lbs)



Procella P8 dimensions  
P8\_vue.CAD  
Anders Uggeberg 23/7-11  
UPD: 25/1-12  
Scale 1:10 (PDF/JPG-file not to scale)